

ZONE		REV.	REVISIONS	DATE	APPROVED
		A	DESCRIPTION REDRAWN IN CAD	6/25/10	WEI

NOTES:

- THIS IS A PRESSURE TOP, SIDE SEAL FINISH AND SHOULD BE SMOOTH AND FREE FROM ANY DEFECTS THAT WILL CONTRIBUTE TO LOSS OF PRESSURE. FLASH NOT TO EXCEED .005" PER SIDE AND CAN NOT BE CONTINUOUS.
- REQUIREMENTS FOR GOOD APPLICATION ON FINISH:
  - .005" MAX. OUT-OF-PARALLEL SEALING SURFACE WITH NECK SUPPORT RING. THIS IS FOR COCKED NECKS AND SLANTED FINISHES.
  - .125" MAX. OUT-OF-PERPENDICULAR WHEN BOTTLE LEANS FROM THE BASE OF THE BOTTLE THROUGH THE FINISH. AN OFFSET OR VERTICAL MISMATCH OF THE THREADS MUST NOT EXCEED .004" AT THE MOLD SEAM.
  - SEAM FLASH PROJECTING INTO THE FINISH AREA MUST NOT INTERFERE WITH THE APPLICATION OR REMOVAL OF THE CLOSURE.
- THREAD FINISH: 720° THREAD LENGTH (MIN. TWO FULL TURNS).
- AN UNDER-MINIMUM 'E' DIAMTER WILL CONTRIBUTE TO LEAKERS.
- PARTING LINE MISMATCH MUST NOT EXCEED .005".
- THESE DIMENSIONS MUST NOT EXCEED THE MAX. CONDITION. IT IS RECOMMENDED THAT THEY BE FORMED AS SHARP/FLAT AS POSSIBLE.

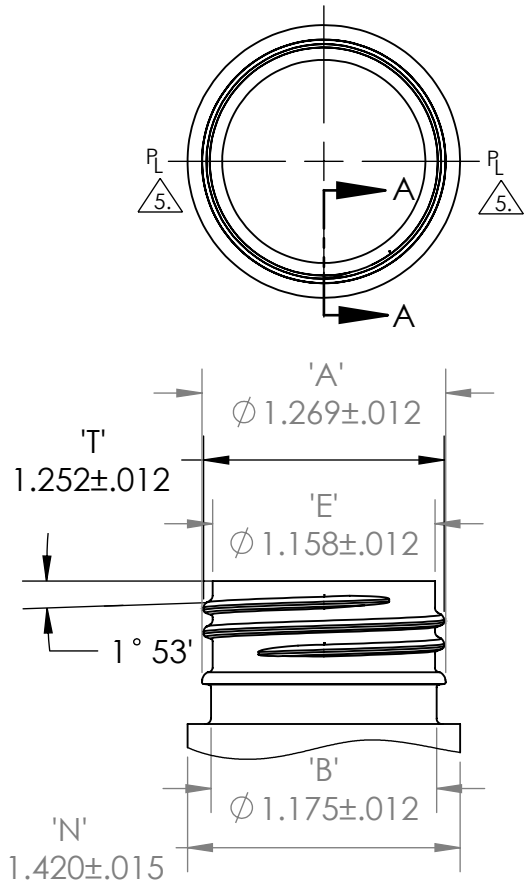
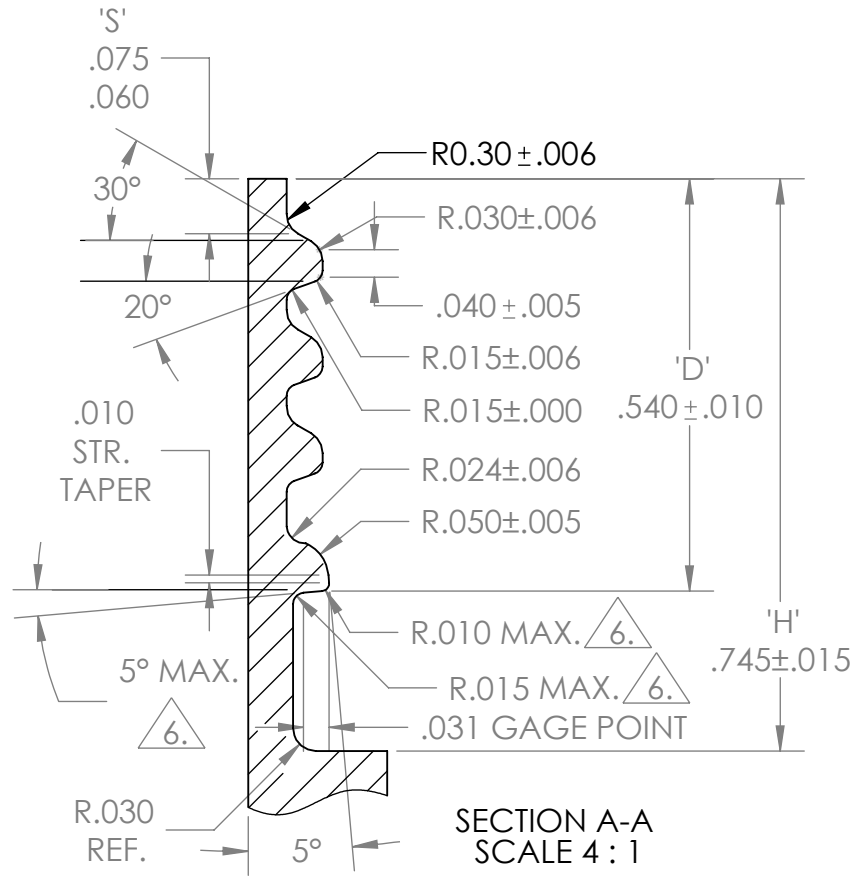

UNLESS OTHERWISE SPECIFIED:		NAME	DATE
DIMENSIONS ARE IN INCHES		DRAWN WEI	6-25-10
TOLERANCES:		DESIGN APPROVED	
FRACTIONAL ±		COMMENTS:	
ANGULAR: ± 1°			
TWO PLACE DECIMAL ±.010			
THREE PLACE DECIMAL ±.005			
INTERPRET GEOMETRIC TOLERANCING PER:			
MATERIAL			
FINISH			
DO NOT SCALE DRAWING			

Hoffer Plastics Corp. 500 N. Collins St. So. Elgin, Il. 60177			
TITLE: <b>POLYETHYLENE FINISH FOR 33MM UNI-LOK CLOSURE</b>			
SIZE <b>A</b>	DWG. NO. <b>1824</b>	REV <b>A</b>	
SCALE: 1:1	Shrink:	SHEET 1 OF 1	

**PROPRIETARY AND CONFIDENTIAL**  
THE INFORMATION CONTAINED IN THIS DRAWING IS THE SOLE PROPERTY OF HOFFER PLASTICS CORP. ANY REPRODUCTION IN PART OR AS A WHOLE WITHOUT THE WRITTEN PERMISSION OF HOFFER PLASTICS CORP. IS PROHIBITED.